

# Dreamtale

## Input list & Stage plot

Ch	Patch	+48V	Instr.	Input	Stand	Insert
1			BD	B52	SB	exp./comp
2			BD Trigg	D.I. (own)		exp./comp
3			SN	e604		exp./comp
4			Piccolo Tom	e604 / SM57	TB	gate
5			Tom 1	e604		gate
6			Tom 2	e604		gate
7			Tom 3	e604		gate
8			Tom 4	e604		gate
9		X	OH L	SM81	TB	
10		X	OH R	SM81	TB	
11			Bass	D.I. (own)		comp
12			GTR L	D.I. (own)		
13			GTR R	D.I. (own) / e906 *	(SB)	
14			KEYB 1 (Str L)	D.I. (own)		comp
15			KEYB 2 (Str R)	D.I. (own)		comp
16			B-Voc L	e935	TB	
17			Lead Voc	e935	TS	comp
18			B-Voc R	e935	TB	
19			HD 1 (mono)	D.I. (own)		
20			HD 2 (mono)	D.I. (own)		

\* Depending on the size of the stage

SB=short boom

TB=tall boom

TS=tall stand (straight)

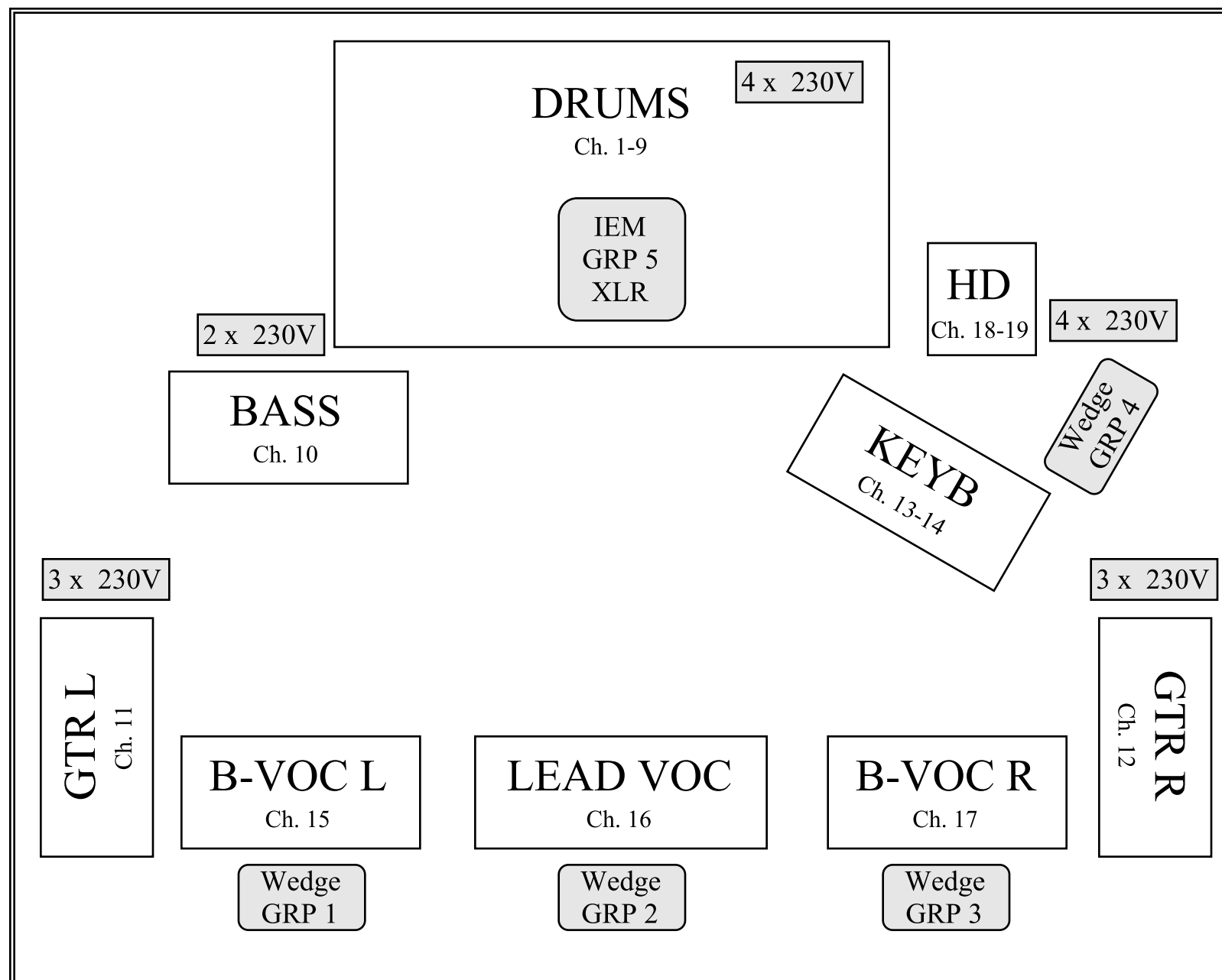

Mics are only as a reference, any factory-made mics are possible. All equipment should be fully functional. If there are any unusual equipment, there should also be an engineer who knows how to use them.

Drummer has an in-ear monitor, so there must be one return available for him. We need at least 5 separate monitor groups in all.

Guitarists and the bass player have wireless systems, frequencies can be changed with some limitations.

If you have any questions, please contact me by email or by phone

Taija Lankinen, FOH  
 lankinentaija@gmail.com  
 +385 46 598 0039

Updated 24.09.2015